

# One New Change calibrated energy model: Post occupancy performance modeling

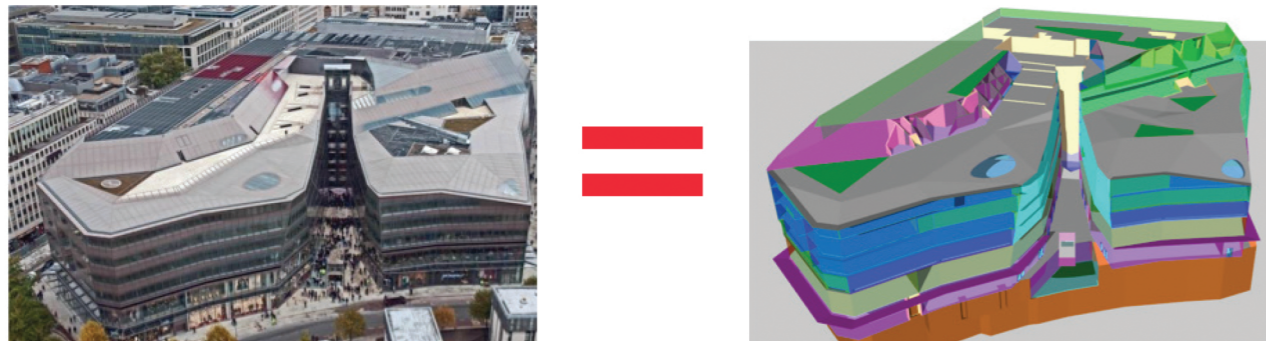

METERING



UTILITY BILLS



BMS



EQUIPMENT



WEATHER

**One new change** is a recent development comprising 4 floors of office space over 3 floors of retail. An extensive network of 13 GSHP systems serves the retail heat pump systems via a condenser loop and the office areas via heat exchangers. The GSHP systems are backed up by gas fired boilers and chillers.

Whilst the overall simulated performance matches well with the actual performance, good agreement was also found in the detailed performance of individual components and process.

The maximum monthly energy deviation was 12%, due in large part to a January billing error. Overall energy cost difference was measured at 2.5%.

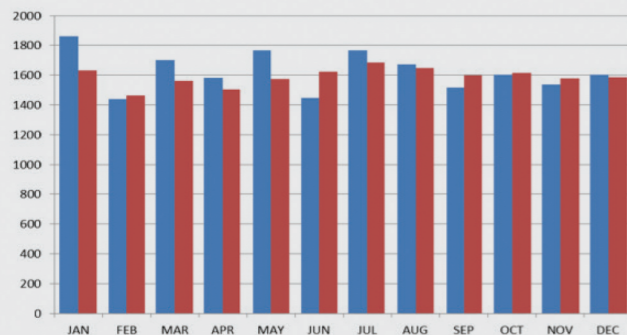

Monthly Energy Consumption (MWh)

■ actual ■ simulated in Tas

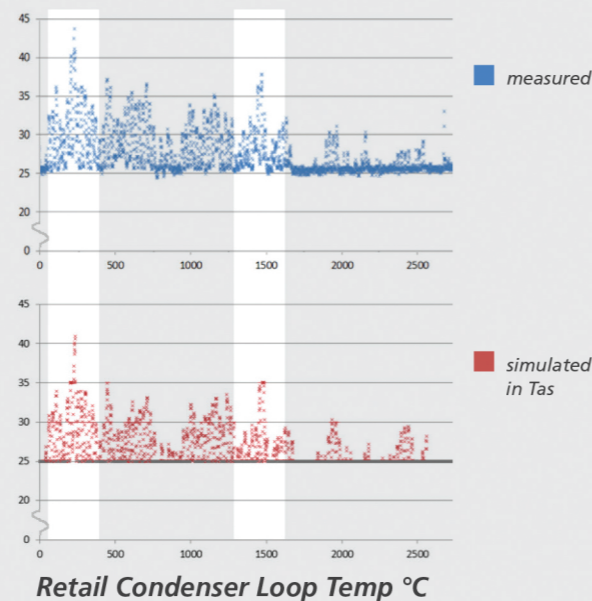

Retail Condenser Loop Temp °C

Measured data of the retail condenser loop and ground loop temperatures correlate closely with the calibrated model simulated in Tas.

The calibrated model was used to optimise the operation of the GSHP systems, improve occupant comfort through humidity control changes, and save a total of \$260,000 on annual running costs.

See the full Technical Briefing on our website.



FAST AND ROBUST BUILDING SIMULATION SOFTWARE

Early Design  
HVAC Design  
LEED and Documentation  
Works with e+ & eQuest

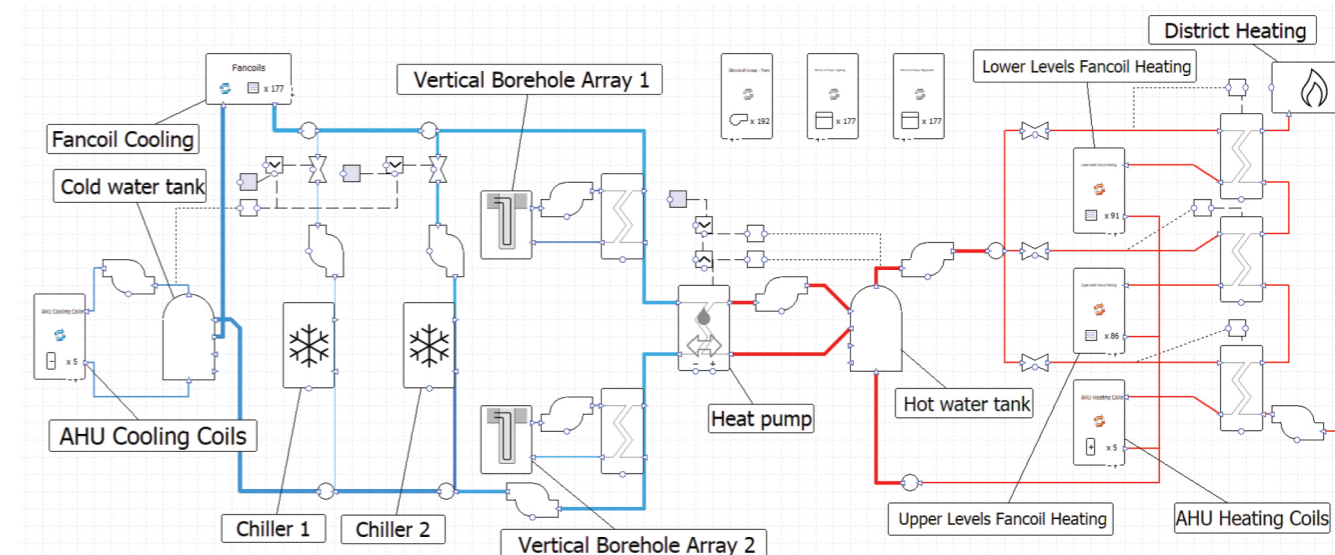
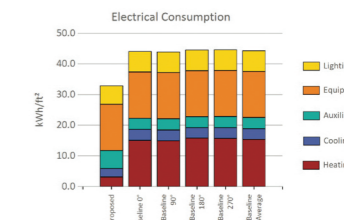
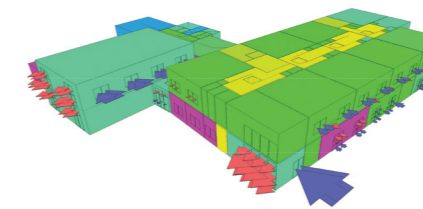

**IT CAN BE DONE!**



Monthly subscription with full maintenance & support from \$330  
Video and Workbook Training Material Included